

DETERMINATION OF OZONE

BY ULTRAVIOLET ANALYSIS

*A New Method for
Volume II, Ambient Air Specific Methods,
Quality Assurance Handbook for Air Pollution Measurement Systems*

Final Draft, May 1, 1997

Prepared by:

Frank McElroy, EPA/NERL, Research Triangle Park, NC

Dennis Mikel, Ventura County APCD, Ventura, CA

Monica Nees, EPA/OAQPS, NCBA, Research Triangle Park, NC

CONTENTS

FIGURES	iii
TABLES	iv
1.0 SCOPE AND APPLICABILITY	1
1.1 Introduction	1
1.2 Method Overview	1
1.3 Format and Purpose	1
2.0 SUMMARY OF METHOD	2
2.1 Historical Review	2
2.2 Ultraviolet Absorption by Ozone	2
3.0 DEFINITIONS	4
4.0 HEALTH AND SAFETY WARNINGS	5
5.0 CAUTIONS	6
6.0 INTERFERENCES	7
6.1 Overview	7
6.2 Water Vapor	7
6.3 Aromatic Hydrocarbons	9
6.4 Mercury	10
7.0 PERSONNEL QUALIFICATIONS	11
8.0 APPARATUS AND MATERIALS	12
8.1 Monitoring Apparatus	12
8.2 Calibration Apparatus	13
8.3 Materials	14
9.0 ANALYZER CALIBRATION	15
9.1 Calibration Standards	15
9.1.1 Primary Standards	17
9.1.2 Standard Reference Photometers	17
9.1.3 Local Primary Standard	17
9.1.4 Verification of Local Primary Standard	17
9.1.5 Ozone Generators	18
9.1.6 Transfer Standards	18
9.1.7 Calibration/Certification of Transfer Standards	19
9.2 Ozone Analyzer Calibration	22

9.2.1	Multipoint Analyzer Calibrations	23
9.2.2	Level I Calibrations	24
9.2.3	Calibration/Certification of On-Site Transfer Standard	24
9.2.4	Level II Zero/Span Checks	25
10.0	ANALYZER OPERATION AND MAINTENANCE	26
10.1	Typical Analyzer Cycle	26
10.2	Routine Checks	27
10.3	Preventive Maintenance	28
11.0	HANDLING AND PRESERVATION	29
12.0	SAMPLE PREPARATION AND ANALYSIS	30
13.0	TROUBLESHOOTING	31
13.1	Environmental Factors	31
13.2	General Factors	31
13.3	Instrument Troubleshooting	31
14.0	DATA ACQUISITION, CALCULATIONS, AND DATA REDUCTION	33
14.1	Data Acquisition	33
14.2	Calculations and Data Reduction	33
15.0	COMPUTER HARDWARE AND SOFTWARE	34
16.0	DATA MANAGEMENT AND RECORDS MANAGEMENT	35
16.1	Data Management	35
16.2	Records Management	35
17.0	QUALITY ASSURANCE AND QUALITY CONTROL	36
17.1	Quality Assurance	36
17.1.1	Precision	36
17.1.2	Accuracy	36
17.1.3	Representativeness	38
17.1.4	Completeness	38
17.1.5	Comparability	38
17.1.6	Method Detection Limit	38
17.2	Quality Control	38
17.2.1	Documentation	38
17.2.2	Standard Operating Procedures	39

REFERENCES 40

Draft

FIGURES

<u>Figure</u>		<u>Page</u>
9.1	Interrelationships among standards used in ozone analysis	15
9.2	Calibration of an ozone analyzer-type transfer standard	20
9.3	Calibration of a photometer-type transfer standard	21
9.4	Calibration of an ozone generator-type transfer standard	21
9.5	DAS calibration system	24
10.1	Ozone analyzer	26
10.2	Example of a quality control and maintenance record	27
16.1	Data flow through a data acquisition system	35

TABLES

<u>Table</u>		<u>Page</u>
3-1	Definitions of Key Terms	4
9-1	Calibration Requirements for Ozone	16
10-1	Example of a Preventive Maintenance Schedule for Ozone Monitoring	28
13-1	Instrument Troubleshooting for Ozone	32
17-1	Data Quality Requirements for Ozone	37

DETERMINATION OF OZONE BY ULTRAVIOLET ANALYSIS

1.0 SCOPE AND APPLICABILITY

An overview of the health and environmental effects of ozone and a summary of the analytical method are followed by a description of the format and purpose of the document.

1.1 Introduction

Ozone (O₃), a colorless gas, has both beneficial and detrimental effects on human health and the environment. Ozone naturally occurring in the upper atmosphere protects humankind against skin cancer caused by ultraviolet radiation from the sun. But ozone resulting from human activity at or near ground level is the principal constituent of smog, which adversely affects respiratory health, agricultural crops, and forests.

Ozone in smog is formed by sunlight reacting with oxides of nitrogen (NO_x) and volatile organic compounds (VOCs) discharged into the air from gasoline vapors, solvents, fuel combustion products, and consumer products. The many originating sources include large industrial plants, gas stations, motor vehicles, and dry cleaners. Atmospheric conditions frequently transport precursor gases emitted in one area to another where the ozone-producing reactions actually occur.

1.2 Method Overview

This method for the determination of ozone (O₃) by ultraviolet (UV) analysis, though new to the Handbook, is not new to the ambient air monitoring community. It has been widely used for almost 20 years instead of the chemiluminescence reference method, which was Test Method 2.7 in earlier Handbook editions. Recent increased attention to the environmental effects of ozone prompted preparation of this UV method now.

The detection limit for ozone is 0.005 ppm (*Code of Federal Regulations*, Volume 40, Part 53.23b, or, in the shortened format used hereafter, 40 CFR 53.23b). For reference, the ozone standard in 1996 is 0.12 ppm, averaged over 1-hour intervals, to be exceeded no more than once per year (40 CFR 50.9).

1.3 Format and Purpose

The sequence of topics covered in this ozone by UV method is different from that found in earlier editions of the Handbook. It follows 1995 EPA guidance on preparing standard operating procedures (SOPs). Agencies can follow the guidance presented here step by step when writing their own SOPs. However, the method was **not** designed to **be** their SOPs.

This method was also written to help field operators understand **why** (not just **how**) key procedures are performed. Special attention is paid to interferences, equipment selection, and, most importantly, calibration procedures.

Throughout, there are many cross references to other sections in this method and to Part I, General Principles, of Volume II, which contains detailed information pertinent to all methods, not just ozone. Cross references to other sections of this **method** are cited simply by section number. For instance, "See also Section 6" refers to Section 6, Interferences. But "See also Part I, Section 6" means Part I, **General Principles**, Section 6, Sampling Design.

2.0 SUMMARY OF METHOD

After a brief historical review in Section 2.1, the current method used for ultraviolet (UV) analysis of ozone is summarized in Section 2.2.

2.1 Historical Review

The ozone reference measurement principle and calibration procedure, promulgated in 1971 and amended in 1979, is based on detection of chemiluminescence resulting from the reaction of ozone with ethylene gas. Later, Rhodamine B, an organic dye embedded in a disc, was approved for use in place of ethylene to detect chemiluminescence. But neither method was problem-free. The flammability of ethylene was a constant concern, especially when monitoring was conducted in or near a public facility. The Rhodamine B analytical system did not regain a stable baseline rapidly enough after exposure to ozone. Thus, when UV analyzers were first approved as equivalent methods in 1977, they gained rapid, almost universal acceptance. Today, users have their choice of many approved UV instruments from several manufacturers. For more information on reference and equivalent methods, see Part I, Section 7.3.

2.2 Ultraviolet Absorption by Ozone

The analytical principle is based on absorption of UV light by the ozone molecule and subsequent use of photometry to measure reduction of the quanta of light reaching the detector at 254 nm.¹ The degree of reduction depends on the pathlength of the UV sample cell, the ozone concentration introduced into the sample cell, and the wavelength of the UV light, as expressed by the Beer-Lambert law shown below:

$$I = I_0 \exp(-\alpha LC)$$

where:

I	=	light intensity after absorption by ozone
I ₀	=	light intensity at zero ozone concentration
α	=	specific ozone molar absorption coefficient
L	=	pathlength, and
C	=	ozone concentration

The air sample is drawn into an optical absorption cell where it is irradiated by a low pressure, cold cathode mercury vapor lamp fitted with a Vycor sheath to filter out radiation with a wavelength of less than 254 nm. A photodetector, located at the opposite end of the sample cell, measures the reduction in UV intensity at 254 nm caused by the presence of ozone in the sample cell. To compensate for possible irregularities in output, another photodetector is used in some instruments to monitor the intensity of the mercury vapor lamp.

Although some ozone analyzers measure reference and sample air simultaneously using two absorption cells, most analyzers alternate these measurements, using only one cell. In the first part of the cycle, sample air is passed through a scrubber with manganese dioxide to remove ozone. The scrubbed sample air then enters the sample absorption cell to establish a reference light intensity at zero ozone concentration (I₀). In the second part of the cycle, sample air is re-directed to bypass the scrubber and enter the sample cell directly for measurement of the attenuated light intensity (I). The difference is related to the ozone concentration according to the Beer-Lambert law shown above. Thus, ozone in a sample stream can be measured continuously by alternately measuring the light level at the sample detector, first with ozone removed and then with ozone present.

Any ozone analyzer used for routine ambient air monitoring must be calibrated against a suitable ozone primary standard or a secondary standard directly traceable to a primary standard. An ozone primary standard is a photometer similar to a UV analyzer that meets the specifications in 40 CFR 50, Appendix D. See Section 9 of this UV method for a description of the various types of standards that are used in the measurement of ozone concentrations.

Potential interferences to the UV detection of ozone, including water, aromatic hydrocarbons, and mercury, are discussed in Section 6.

Direct

3.0 DEFINITIONS

Learning new acronyms, abbreviations, and specialized terms is an important task of a new staff member because these items are a part of the organizational culture. But if these terms are not somewhat intuitive and are not defined in writing, they will remain unintelligible jargon. Part I, Page viii lists the many acronyms and abbreviations used in the QA Handbook. Standard operating procedures (SOPs) should contain similar lists of terms specific to them, while also defining each term upon first usage in the document.

Any commonly used shorthand designations for items such as the sponsoring organization, monitoring site, and perhaps even the geographical area need to be included in SOPs. Even more important are names and special terminology for equipment and systems and for terms specific to a method. Here are some key terms for this method.

Table 3-1. Definitions of Key Terms

Term	Definition
DAS	Data acquisition system. Used for automatic collection and recording of ozone concentrations. (See also Section 14).
Interferences	Physical or chemical entities that cause ozone measurements to be higher (positive) or lower (negative) than they would be without the entity. (See also Section 6).
Local primary standard	Master standard for all calibrations by a monitoring agency. NIST-traceable when verified by comparison to a standard reference photometer, usually through a transfer standard. Must meet requirements found in 40 CFR 50 Appendix D. (See also Section 9.1.3).
NIST	National Institute of Standards and Technology (formerly the National Bureau of Standards.) Holder of the standard reference photometer for establishing NIST traceability. (See also Section 9.1.2).
Ozone analyzer	Designation reserved for an air monitoring instrument. (See also Sections 8.1, 9.2, and 10).
Ozone photometer	Designation reserved for a UV instrument used as a primary or transfer standard. (See also Section 9.1.1 through 9.1.5).
SRP	Standard reference photometer. (See also Section 9.1.2).
Transfer standard	A transportable device or apparatus which, together with associated operational procedures, is capable of accurately reproducing ozone concentrations or of producing accurate assays of ozone concentrations which are quantitatively related to an authoritative master standard. ² (See also Sections 9.1.5 through 9.1.7).
Zero air	Must be free of ozone, to 0.001 ppm, and of substances that react with ozone, including nitric oxide (NO), nitrogen dioxide (NO ₂), particulates, and hydrocarbons. (See also Section 8.2).

4.0 HEALTH AND SAFETY WARNINGS

To prevent personal injury, all warnings must immediately **precede** the applicable step in an SOP. The following warnings should be heeded and any others should be added.

- ! **Ozone is a very strong oxidant.** Vent any ozone or calibration span gas to the atmosphere rather than into the shelter or other immediate sampling area. If this is impossible, limit exposure to ozone by getting fresh air every 10 to 15 minutes. If chest tightening occurs, leave the area immediately.
- ! **Ultraviolet light can cause burns to the cornea of the eye.** Avoid looking at the UV lamp when it is on. Use protective glasses if the lamp must be checked when it is energized.
- ! **Always use a third ground wire on all instruments.**
- ! **Always unplug the analyzer when servicing or replacing parts.**
- ! **If it is mandatory to work inside an analyzer while it is in operation, use extreme caution to avoid contact with high voltages inside the analyzer.** The analyzer has high voltages in certain parts of the circuitry, including a 220 volt DC power supply, a 110 volt AC power supply, and a start-up lamp voltage of more than 1000 volts. Refer to the manufacturer's instruction manual and know the precise locations of these components before working on the instrument.
- ! **Avoid electrical contact with jewelry.** Remove rings, watches, bracelets, and necklaces to prevent electrical burns.

5.0 CAUTIONS

To prevent damage to the equipment, all cautions must immediately **precede** the applicable step in an SOP. The following precautions should be taken, and any others added.

- ! Clean the optical tubes carefully to avoid damaging the interior of the tubes. Use cleaning procedures outlined in the manufacturer's instruction manual.
- ! Keep the interior of the analyzer clean.
- ! Inspect the system regularly for structural integrity.
- ! To prevent major problems with leaks, make sure that all sampling lines are reconnected after required checks and before leaving the site.

6.0 INTERFERENCES

Preventing interferences is crucial to the accurate measurement of ozone. This section describes the three most common interferences--water vapor, aromatic hydrocarbons, and mercury--and recommends procedures to minimize these interferences.

6.1 Overview

UV ozone analyzers measure ozone concentration by absorption of electromagnetic radiation at a wavelength of 254 nm. Any other gas in the air sample that also absorbs at that wavelength could present an interference. The UV analyzer operates by comparing absorption measurements of the sample air with measurements of the same sample air after removal of only the ozone by an ozone scrubber.

Ideally, a gas that absorbs at 254 nm will do so equally in both measurements, and the effect will cancel. The scrubber must remove 100% of the ozone while quantitatively passing other gases that absorb at 254 nm. Some gases, however, may be partially or temporarily absorbed or adsorbed by the scrubber, such that their concentration is not equal in both measurements. An interference can occur when a gas absorbs at 254 nm or produces some other physical effect (such as water condensing on scratches in the cell window), and does not pass freely through the ozone scrubber. Hence, proper scrubber performance is critical to minimizing interferences.

Negative interferences result from incomplete removal of ozone by the scrubber and from loss of ozone by reaction or adsorption in dirty inlet lines, filters, analyzer plumbing components, and the measurement cells, particularly with long residence times. Condition all sample lines and filters by exposing them to high concentrations of ozone (>400 ppm) for at least 30 minutes. New tubing and filters that are not conditioned will take up ozone for some time.

Ozone breakthrough has been shown to be a transient problem occurring primarily under humid conditions. Before use in high humidity environments, new scrubbers may need to be pre-treated by proprietary methods recommended by the manufacturer to saturate ozone adsorption or reaction sites. Ozone breakthrough can also occur in dry conditions if the scrubber is not replaced according to the manufacturer's recommended schedule.

Three common positive interferences for UV ozone analyzers are discussed below. This information is based on review articles^{3,4,5,6} and on operators' experiences, including anecdotal reports. Check the cited references for additional information. Specific data on some interferences are substantially incomplete. The guidance provided here is the current best judgement based on available information and is subject to modification pending availability of further data.

Operators are encouraged to report any observations or anecdotal data that might add to the understanding or awareness of interferences or other anomalies in ozone measurements with UV analyzers. Send this information to the office shown in Part I, Foreword, Page ii where it will be incorporated with other reports and made available through documents such as this one, the Ambient Monitoring Technology Information Center (AMTIC), and the Internet to benefit all members of the ozone monitoring community.

6.2 Water Vapor

A recent study³ showed conclusively that UV analyzers have negligible interference from water vapor in systems containing only ozone, water vapor, and zero air. The measured ozone concentrations were within 0.5 percent of the true ozone values at various test humidities. Even condensed water in the sampling line did

not cause high ozone readings. This lack of water vapor interference is expected because water vapor absorption in the UV region is negligible above 186 nm. In contrast, chemiluminescence analyzers have a well-documented water interference of about 3 percent per percent water in the air, over a range of 1 to 3 percent water, corresponding to dew point temperatures from about 9 to 24°C.⁴

Water vapor, however, can nevertheless affect UV-based ozone measurements under some conditions. When the humidity of the sample air is high enough to approach saturation, condensation of water may occur at various points in the sampling system or analyzer. Further, water vapor may be absorbed by the scrubber such that some period of time is required before the air leaving the scrubber is at the same humidity as the sample air. At high humidity, condensation can also occur on scratches in the cell windows.⁷ During transition periods when the humidity of the sample air is increasing, such condensation may even occur during the sample air measurement but not during the zero ozone measurement, resulting in a positive interference.

High humidity or condensation in the sample air may also affect the ability of the scrubber to pass other potentially interfering gases, such as aromatic hydrocarbons, discussed in Section 6.3. Although condensed water did not affect ozone measurements in clean air tests³, condensation in a dirty inlet line and other inlet components—especially particulate filters—is notorious for reducing measured ozone concentrations. Large amounts of liquid water can reduce or prevent sample air flow in inlet lines and filters and may cause damage to the analyzer cells or windows if it enters the analyzer.

Geography can influence the time of day of peak dew point temperatures. For example, in the eastern United States, dew point temperatures peak on hot summer afternoons, particularly with rain showers in the area, just at the time when peak ozone concentrations are likely to occur and when measurement accuracy is critically important. In the western United States, especially in southern California coastal basins, dew point temperatures are highest in the pre-dawn to mid-morning hours, but ozone concentrations are highest in the early afternoon. In the dry Southwest, however, water vapor interference is rarely a problem.

Data quality will be enhanced by following the recommendations below.

- ! Operate UV ozone analyzers to avoid condensation of moisture anywhere in the analyzer, sample inlet line, or inlet filter. Condensation may first occur in the particulate filter because the slight pressure drop there favors it. The best way to avoid condensation in the inlet sample air is to assure that the temperatures of all locations in the analyzer and sample inlet line remain above the dew point temperature of ambient air.
- ! Maintain the monitoring shelter at temperatures no lower than 26-27°C (79-81°F), if possible, in areas where dew point temperatures are high. Outdoor ambient air dew point temperatures can exceed 27°C (80°F) on hot, summer days, particularly in coastal areas or following rain.
- ! Make sure that air conditioners or cool air ducts do not blow directly on the analyzer or on the inlet line. Use a thermograph to monitor the shelter temperature near the analyzer for several days under a variety of weather conditions to ensure that the temperature does not get too low or too high when the air conditioner cycles on and off.
- ! Check the particulate filter and lines frequently for condensation, especially at times when the outdoor dew point temperatures are likely to be the highest (afternoons or hot, rainy days). Today's condensation may be gone by tomorrow.

- ! Record the ozone analyzer output using a strip chart recorder, data logger with graphics capability, or similar method to plot 1-minute digital data for several days during humid weather. Look for abnormal characteristics such as cyclic patterns, long periods with little or no change in concentration, or unusually low readings when higher readings would be expected. These patterns are easily detectable on a graphical plot but may not be recognizable in raw digital data. Cyclic patterns, for instance, are frequently synchronized with the on-off cycles of the shelter air conditioner. All abnormal patterns should be investigated to see if they also represent errors in the ozone measurements.

- ! Wrap the inlet line and sampling manifold with thermal insulation if condensation is observed in the inlet line or particulate filter, and if the shelter temperature cannot be increased. In extreme cases, the inlet lines may be heated **slightly** above ambient temperature with heating tape, but finding a heater of low enough wattage to do so may be difficult. Heating must be done very cautiously, because the lines should be heated no more than 3 or 4 °C (5-7 °F) above ambient temperature. Use a Variac or similar device to control the temperature. Such heating may transfer condensation into the analyzer unless the analyzer is also heated internally about the same amount. How best to effect such a small temperature increase may be equipment-dependent and some experimentation may be necessary. Perhaps an electric light bulb could be placed near the fan or ventilation air inlet of the analyzer or ventilation air flow could be partially restricted. Check the temperature inside the analyzer and experiment until the temperature is raised the right amount. Avoid excessive temperatures to prevent ozone loss.

6.3 Aromatic Hydrocarbons

Many aromatic hydrocarbons are known both to absorb light at 254 nm and to be "sticky"--readily absorbed or adsorbed on surfaces exposed to air samples. Smog chamber studies producing ozone by irradiation of toluene/NO_x mixtures showed that benzaldehyde and other aromatic photooxidation products such as *o*-cresol and *o*-nitrotoluene were almost completely removed by ozone scrubbers used in ozone UV analyzers. Although scrubber retention of aromatic hydrocarbons produces a **positive** interference initially, the retained compounds may be released later when conditions change, giving rise to a **negative** interference. Under humid conditions, compounds may be desorbed from the scrubber.

Generally, aromatic hydrocarbons cannot be significantly removed from air samples without also altering the ozone concentration.³ Therefore the only practical way to avoid interference from these compounds is to avoid siting a UV analyzer in an area that may have significant concentrations of aromatic hydrocarbons.

Problems with hydrocarbon interferences can be minimized by taking the following precautions.

- ! Avoid sites near or downwind from asphalt plants, asphalt paving operations, chemical plants, and similar sources.

- ! Avoid large asphalt areas such as roadways and parking lots that can outgas significant aromatic hydrocarbon concentrations on hot, sunny days.

- ! Avoid local influence from hydrocarbons near motor pools, diesel fueling tanks, gas stations, thruways, tunnels, airports, and other areas of heavy motor vehicle traffic.

- ! Avoid highly urban or heavily polluted areas, if possible, to prevent interference from toluene, an aromatic hydrocarbon normally found in high concentrations in urban atmospheres.

- ! Avoid applying herbicide and pesticide formulations near the monitoring shelter, to prevent interferences from outgassing of hydrocarbons used in the formulations.
- ! Use a non-UV type analyzer when an ozone monitoring site must be located in an area where aromatic hydrocarbon concentrations are high. Chemiluminescence ozone analyzers are not affected by interference from aromatic hydrocarbons and are recommended for such sites, but they are difficult to obtain because few manufacturers still make them. Chemiluminescence analyzers were widely used many years ago, but because they required a supply of ethylene, a flammable and explosive gas, they were replaced by UV analyzers that have no such limitations.

Another alternative is to use an open-path differential optical absorption spectrometer (DOAS) analyzer, which also is not affected by interference from aromatic hydrocarbons. An open-path monitor provides measurements of a more integrated nature and may have different siting requirements than a conventional point monitor. Nevertheless, it can be a good, though expensive, choice.

6.4 Mercury

Interference from mercury is generally not a problem at most sites because atmospheric concentrations are usually very low, but the possibility of locally high mercury concentrations in the vicinity of a monitoring site does exist. Local atmospheric contamination from mercury has been attributed to a wide variety of sources, ranging from dental fillings to herbicides used near a monitoring shelter.⁶ Anecdotal reports also suggest that field operators must be alert to the possibility of abnormal ozone readings caused by mercury vapor from broken equipment such as mercury thermometers. In one case, high ozone readings for nearly a year were attributed to a broken thermometer found on the roof near the sampling intake. In another, low readings were obtained for a week due to a broken thermometer found in a wastebasket inside a shelter where inside air was used to generate zero air. In both cases, ozone readings returned to normal range after the spilled mercury was removed.

Minimize the effect of mercury interference by taking the following precautions.

- ! Keep the monitoring station free of spilled mercury for measurement as well as health reasons.
- ! Inspect the area around a monitoring site for possible contamination from spilled mercury, application or disposal of mercury-containing chemicals, or other sources of possible mercury contamination.
- ! Never use a vacuum cleaner to pick up spilled mercury. More contamination can result if mercury vapor is spread throughout the area and liquid mercury remains in the bag. Instead, use a commercially available mercury clean-up kit that employs sponges and a bulb-type suction device.
- ! Examine ozone measurement data for unusual patterns or verify data with a non-UV ozone analyzer because the evidence of mercury contamination in the area may not be obvious.

7.0 PERSONNEL QUALIFICATIONS

General personnel qualifications are discussed in Part I, Section 4. Any SOP should state explicitly the educational level, training, and experience required for those who will be using it. It should also address special requirements such as certification for use of transfer standards, electronics troubleshooting, and any other topic deemed essential by the monitoring agency.

Draft

8.0 APPARATUS AND MATERIALS

Because of the complexity of ozone monitoring equipment and procedures, this Section includes much more information than the customary list of equipment and supplies, to give field operators an in-depth understanding of their task and tools.

8.1 Monitoring Apparatus

- ! **UV Ozone Analyzer:** Continuous air monitoring analyzers are commercially available from a number of vendors. The design of a UV ozone analyzer is similar to that of the photometer described in Section 9.1.1 but with one important difference. An ozone analyzer uses a special internal scrubber that removes ozone but not other gases to provide a zero-concentration ozone reference for the analyzer's zero reference. Maintaining the distinction between an analyzer and a photometer is very important. The term "analyzer" is reserved for the air monitoring instrument, the term "photometer" for the calibration standard instrument. For use in State and Local Air Monitoring Stations (SLAMS) networks, an analyzer must be one designated by EPA as an equivalent method under 40 CFR 53 (40 CFR 58, Appendix C, Section 2.1.) See also Part I, Section 7.3.

Ozone analyzers have three major systems: the optical system (or "optic bench", as frequently used by the instrument manufacturers), the pneumatic system, and the electronic hardware. Each is described below.

(1) Optical System: Generally consists of the measurement cell or cells, a UV lamp, and a UV detector. The cells are usually made of aluminum, glass, or stainless steel tubes that can be sealed against leakage; the ends are either open or made of glass. The internal cell coating can vary, including Kynar, Teflon, glass, or stainless steel. The system should be easily accessible for preventive maintenance because particulate matter can collect in the cells and affect transmittance of light.

(2) Pneumatic System: Consists of sample probe, sample inlet line, particulate filter, solenoid valves, scrubber, internal tubing, flowmeter, and pump, all used to bring ambient air samples to the analyzer inlet.

(3) Electronic Hardware: The part of the analyzer that generally requires little or no maintenance. If the instrument is operated above the manufacturer's recommended temperature limit, however, individual integrated chips can fail and cause problems with data storage or retrieval.

Other apparatus and equipment includes the following.

- ! **Instrument Shelter:** A shelter is required to protect the analyzer from precipitation and adverse weather conditions, maintain operating temperature within the analyzer's temperature range requirements, and provide security and electrical power. The recommended shelter temperature range is 20-30°C. See also Part I, Section 7.1, and the manufacturer's operating manual for the analyzer.
- ! **Spare Parts and Incidental Supplies:** Replacements should be available for the ozone scrubber, UV lamp, particulate filters, cell cleaning supplies, etc. See the analyzer's operating manual for specific maintenance and replacement requirements.

- ! **Data Acquisition Device:** Many types of equipment can be used to record the concentration measurements obtained from the analyzer. See also Part I, Section 14.

8.2 Calibration Apparatus

The following equipment is required for calibration of an ozone analyzer.

- ! **Ozone Transfer Standard:** A transfer standard, such as an ozone analyzer or ozone generator, that has been certified as a transfer standard against the local primary standard in accordance with stipulated procedures.² A primary ozone standard may also be used directly for calibration, in which case it should be intercompared periodically with another primary ozone standard to check its veracity.⁸
- ! **Ozone Generator:** A generator providing stable ozone concentrations that can be varied manually or by automatic electronic feedback circuitry. If the transfer standard is an ozone generator, no other ozone generator is needed.
- ! **Zero Air Generator:** Zero air is required for the calibration of ozone instruments. This air must be ozone-free to 0.001 ppm, and also free of nitric oxide (NO), nitrogen dioxide (NO₂), particulates, and hydrocarbons. Although there are many commercially available zero-air systems, zero air can also be generated by using a series of canisters that contain thermally cracked carbon, Purafil, and desiccant. Because NO may be difficult to remove, frequent changing of the carbon or use of an NO-to-NO₂ converter may be necessary. When such a converter is used, test the output with an NO/NO_x analyzer to ensure that the residence time in the system is long enough for complete conversion of NO to NO₂.

The desiccant used with the zero-air system should be changed regularly. A canister system set up with a pump and surge tank can provide a cost-effective zero-air system. If a zero-air system is created, the moisture content must remain constant. Changing humidity can affect the response of UV photometers. Very dry zero air may also be a problem. The scrubber needs time to adjust if the zero air is much drier than the ambient air.

- ! **Output Manifold:** Although the output manifold can be constructed of borosilicate glass, Teflon, or stainless steel, glass is recommended. The manifold must have an opening that vents excess air to the atmosphere such that the pressure in the manifold is as close to atmospheric pressure as possible. If ozonated air is delivered under too high a pressure, the ozone readings obtained will not be representative. Manifolds collect particulate matter on the internal walls because neither zero air nor sample air is totally particulate-free. Because stainless steel or Teflon manifolds are opaque, it can be difficult to determine whether they are collecting particulates. A transparent glass manifold can be inspected easily and cleaned readily by rinsing with distilled water and air drying. But use caution with glass manifolds because of their fragility.
- ! **Barometer:** The internal barometric pressure of a transfer standard needs to be determined accurately if measurements are made above 1000 feet in elevation (approximately 730 mm Hg). Many commercially available analyzers or photometers with built-in barometric pressure sensors automatically correct the measured ozone values to 760 mm Hg. If automatically adjusting instruments are not available, pressure corrections need to be made manually.
- ! **Temperature Sensor:** The internal temperature of a photometer must be measured accurately. Many newer photometers have built-in temperature sensors to automatically correct the measured

ozone values to 298°K. If automatic adjusting instruments are not available, temperature corrections need to be made manually.

8.3 Materials

- ! ***Tubing and Fittings:*** Teflon and Kynar are two inert materials that should be used exclusively throughout the system. Stainless steel tubing should be avoided because it is expensive, hard to clean, and can develop micro-cracks that are difficult to detect. Teflon tubing is the best choice because it can be examined and discarded if particulate matter is collecting in it. It is also very pliable. All fittings and ferrules must also be made of Teflon or Kynar.

9.0 ANALYZER CALIBRATION

Table 9.1 summarizes the many calibrations requirements for the UV analysis of ozone. The text of this Section then describes these requirements in detail.

9.1 Calibration Standards

No Standard Reference Materials (SRMs) exist for ozone because ozone is unstable in cylinders. Therefore, ozone standard concentrations must be generated dynamically *in situ*, either with (1) an ozone generator certified as an ozone transfer standard; or (2) an uncertified ozone generator whose output concentration levels are assayed with a primary standard photometer or an ozone assay instrument certified as an ozone transfer standard. See Figure 9.1 for an overview of the interrelationships among standards.

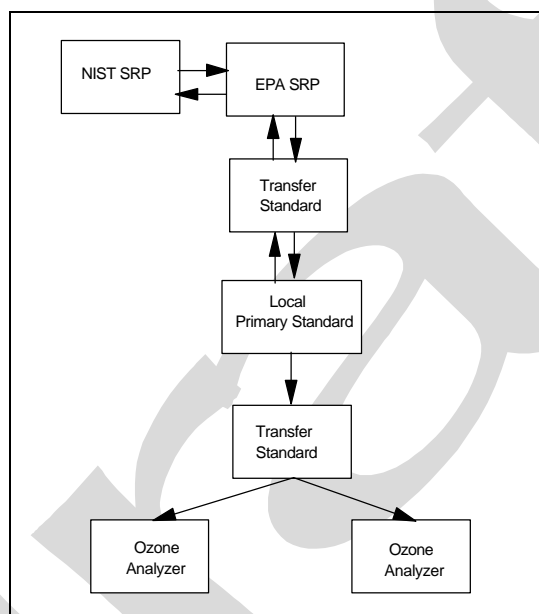

Figure 9.1 Interrelationship among standards used in ozone analysis

Ozone can be generated by irradiating zero air with UV light from a cold cathode mercury vapor lamp. To be useful for calibration, the generated ozone concentrations must be stable and reproducible over a 15- to 30-minute time period. The ozone concentration can be modulated in several ways: (1) increasing or decreasing the intensity of the lamp to raise or lower the ozone concentration while keeping the air flow constant; (2) increasing or decreasing the air flow while keeping the lamp intensity constant; and (3) mechanically altering the intensity of the radiation using a variable shutter or sleeve. Most commercially available calibration systems with internal ozone generators modulate the ozone concentration by changing the intensity of the generating lamp electronically.

Table 9.1 Calibration Requirements for Ozone

Requirement	Frequency	Acceptance Criteria	Reference	Information/Action
Calibration Photometer linearity test	?	Linearity error <5%	40CFR 50 App. D, S.5.2.3 ^{1/} EPA-600/4-79-057	Check verify accuracy of flow dilution. Redo analysis. If failure persists corrective action required. See 2nd reference.
Transfer standard Qualification -Precision	1/3 mo.	4% ±4ppb (whichever greater) RSD of slope ≤ 3.7%	EPA-600/4-79-056 S.4 EPA-600/4-79-056 S.6.5	6 comparison runs that include, at minimum, 6 concentrations including 0 and 90 ± 5% of upper range.
Certification to reference standard	1/year	Quantity of intercept ≤1.5% new slope = ±0.05 of previous	EPA-600/4-79-056 S.4 EPA-600/4-79-056 S.6.5	6 comparison runs that include, at minimum, 6 concentrations including 0 and 90 ± 5% of upper range.
Reference Photometer Certification		slope=1±0.01, intercept < 3ppb	Ref 9 of this method.	9 replicate analysis over 12 conc. ranges. Disagreement must be resolved. EPA SRP rechecked with NIST. If OK, network SRP must be repaired.
Zero/Span Check -Level I	1/ 2 weeks	Zero ± 20 ppb Span ± 20 % Zero ± 10 ppb Span ± 15%	Vol II-S.12.6 “ Vol II-S.12.6 “	If calibration updated at each zero/span- Invalidate data to last acceptable check, adjust analyzer, perform multi-point calibration. If fixed calibration used to calculate data. Invalidate data to last acceptable check, adjust analyzer, perform multi-point calibration.
Multipoint	upon receipt upon zero/span adjustment. 1/ 6 mo.		40CFR 50 App. D, S.5.2.3 EPA-600/4-79-057 S.5 Vol II-S.12.2	5 or more upscale calibration points.
Performance Evaluation NPAP State Audits	1/year- selected sites 1/yr	Mean absolute % difference ≤ 15% State requirements	Vol II-S.16.3 No ref.	Use information to inform reporting agency for corrective action and technical systems audits.

^{1/} - reference refers to the QA Handbook for Air Pollution Measurement Systems, Volume II . The use of “S” refers to sections within Part I of the Handbook. The use of “MS” refers to sections of the method for the particular pollutant.

9.1.1 Primary Standards

EPA has established UV photometry as the primary standard for ozone concentrations (40 CFR 50, Appendix D). Ozone primary standard concentrations are determined by a primary standard photometer.⁸ Ozone photometry is based on the Beer-Lambert law explained in Section 2.2. A primary standard ozone photometer is an instrument that measures ozone using the Beer-Lambert law at 254 nm, uses the absorption coefficient for ozone ($308.8 \text{ atm}^{-1}\text{cm}^{-1}$ at 273°K and 760 mm Hg), and meets all other requirements.⁸ Most commercially available photometers make these corrections automatically. An auxiliary ozone generator is also required to provide stable ozone concentrations to be assayed by the photometer.

An ozone standard photometer is very similar to the ozone analyzer described in Section 8.1 but **has no built-in scrubber for removing ozone**. Therefore the photometer must be supplied with zero air from the same source that supplies zero air to the ozone generator.

9.1.2 Standard Reference Photometers

EPA and the National Institute of Standards and Technology (NIST) jointly developed a special, highly accurate standard photometer known as a Standard Reference Photometer (SRP) to serve in lieu of an SRM for ozone concentrations. NIST maintains one or more "master" SRPs. EPA maintains 10 other SRPs: one in Research Triangle Park, NC; seven in EPA Regional Office laboratories; one at the California Air Resources Board; and a traveling one used for intercomparisons. Other SRPs are located in foreign countries.

Each SRP is a standard in its own right and is not "calibrated" against the NIST unit. Instead, all SRPs are intercompared periodically to **verify** that they all agree with one another and to establish NIST-traceability.⁹ If one does **not** agree with the others, it is **not** recalibrated--it is repaired. The EPA SRPs provide NIST-traceable ozone standards that are accessible to states and local agencies for verifying their own local primary standards. In some cases, the SRPs may also be available for certification of transfer standards discussed in Section 9.1.5.

9.1.3 Local Primary Standard

Each monitoring agency needs its own local primary standard photometer that serves as the single master standard for all ozone calibrations carried out by the agency. This local primary standard photometer is operated as described in Reference 8. Other ozone photometers or transfer standards are used as working standards to calibrate the ozone monitoring analyzers. These transfer standards are all referenced to the local primary standard. Calibration photometers are commercially available from a number of vendors, or a UV analyzer can be modified to become a calibration photometer.⁸

9.1.4 Verification of Local Primary Standard

Because even primary standard photometers can malfunction, each local primary standard should be compared at least annually to an SRP to reverify its accuracy and recertify its NIST traceability. Although a local primary standard may be moved to an SRP laboratory for the comparison, a transfer standard that has recently been recertified against the local standard is usually moved instead, to protect the local standard from damage during transit.

The local primary standard photometer is **not calibrated** against a verified SRP, because it is a standard in its own right. Instead, it is compared with the SRP to verify its continued accuracy. **If there is a substantial**

difference (more than $\pm 5\%$, preferably $\pm 3\%$) between the local standard and the SRP, the local standard is considered to be malfunctioning and must be repaired and reverified before further use.¹⁰

In a typical verification of a local primary standard, a six-point calibration (a 1x6) of a transfer standard against the local primary standard is performed throughout the operating range, generally 0-1.000 or 0-0.500 ppm, and including zero, to establish a linear relationship between the transfer standard and the local primary standard. If the transfer standard is an established one with a recent 6x6 calibration (a 1x6 done on six days within a 14-day period using the same ozone concentrations), use that calibration data instead. Then perform a similar comparison of the transfer standard against the SRP.

The two linear regressions (between transfer standard and SRP and between transfer standard and local primary standard) are then compared. If the linear regressions against the transfer standard are **within 1.00 +/- 0.03 on slope and 0.003 ppm on intercept**, then the local primary standard is operating within acceptable limits.

Agencies needing an SRP verification should contact the EPA office shown in Part I, Introduction, Page 2. An SRP laboratory will contact them and provide guidance for conducting the intercomparison.

9.1.5 Ozone Generators

Ozone generators, one type of commonly used transfer standard discussed in Section 9.1.6, frequently are mass flow-controlled calibration units with a very accurate ozone generator system. They operate by establishing the authority of a thumbwheel setting or digital display to the primary standard.

9.1.6 Transfer Standards

A transfer standard is a secondary standard that is used to transfer the accuracy (or authority) of the local primary ozone standard to the ozone analyzers at the monitoring sites. A transfer standard is first calibrated against the local primary standard and then used in the field to calibrate ozone analyzers.²

A transfer standard may be an ozone generator or an ozone photometer. For the latter, a stable auxiliary ozone generator is also required to produce certifiable ozone concentrations. All transfer standards must meet the qualification requirements described in Reference 2. Commercially available transfer standards usually have a built-in ozone generator.

Clean Teflon tubing should be used between the primary and the transfer standards. The zero air should have less than 0.001 ppm of ozone. If the transfer standard has a zero air scrubber, the transfer standard should be plumbed to take in zero air through that scrubber during the zero air cycle. Normal manufacturer's recommended maintenance procedures should be performed for the primary standards and for cleaning the optical system. To eliminate the need for frequent cleaning of the optical system, a Teflon filter (pore size of 10 microns) should be used on the inlet of the primary standard.

Temperature- and pressure-sensing hardware must be calibrated annually. The temperature-sensing unit should be submersible and compared against a NIST-traceable thermometer in water at three different temperatures. The barometer should be compared against a Fortin barometer or equivalent.

9.1.7 Calibration/Certification of Transfer Standards

Several conditions must be met before an instrument can be certified as a transfer standard.

- ! The transfer standard must be capable of generating or assaying ozone concentrations very precisely and repeatably. The same instrument must never be used both as a transfer standard and as an analyzer to collect data. If so, the authority of the transfer standard is voided and can be re-established only by a new comparison.
- ! A transfer standard has no intrinsic authority of its own and must be referenced and certified to a primary standard before use for calibrating analyzers.
- ! Once authority has been established, a transfer standard should be recalibrated or recertified at least every three months against a primary standard.
- ! The pros and cons of several early types of transfer standards, including chemiluminescent analyzers, gas phase titration methods, and the boric acid/potassium iodide (BAKI) method have been discussed in detail.¹¹ But these methods are no longer widely used and are also discouraged from use. Photometers, UV analyzers, and ozone-generating units are now the preferred transfer standards.
- ! Transfer standards are always used with clean, filtered zero air.
- ! A transfer standard can be operated with or without a ozone-zero air scrubber. If a scrubber is used, it should be changed regularly, depending on how much the photometer is used between recertifications and on the manufacturer's recommendation. Scrubbers should be replaced at least annually. If an internal scrubber is not used, then some type of external scrubber, such as activated charcoal in an air-tight canister, is needed during the zero-air cycle. Once certified against a local primary standard, a transfer standard must keep the same scrubber configuration during use.
- ! A transfer standard must be a rugged device readily transportable in airplane cargo holds and motor vehicles, yet light enough to be carried across difficult terrain. It should be shipped in foam-lined, impact-resistant plastic containers, and secured by vehicle seat belts whenever possible.
- ! Documentation of calibration and certification to the local primary standard must always remain with the transfer standard for ready access if data collection procedures are questioned during audits. An accompanying folder or logbook should summarize the tests that have been performed on the instrument to establish authority to a primary standard.

The authority of a transfer standard photometer is established by a 6x6 comparison between the transfer standard and the local primary standard. The ozone can be generated by the transfer standard, primary standard, or an independent ozone generator.² Additional suggestions for enhancing data quality are shown below.

- ! The primary and transfer standards must analyze the same air under the same atmospheric conditions. The manifold to which they are connected must have an opening large enough so that excess air can leave the manifold without any back pressure. Many commercially available photometers have built-in ozone generators and calibration manifolds. If the transfer standard has an ozone generator or manifold, use as short a length of tubing as possible from the manifold to reduce line loss to the standard.

- ! If an independent ozone generator is used, then the lines to the primary and transfer standards should be approximately the same length. Use only Teflon lines.
- ! Use the same zero air for the primary and transfer standards if the zero air scrubber is removed from the transfer standard.
- ! Vent the ozone to the outside, if possible. Ozone exposure in an enclosed area can contribute to health problems, as described in Section 4.
- ! Assign one person (and a back-up) to performing the intercomparisons to reduce problems attributable to operator variability.

Perform a 1x6 comparison by attaching Teflon lines from the inlet of the transfer standard to one manifold port and from the inlet of the primary standard to another port. Thereby, both instruments can sample the atmosphere in the manifold simultaneously. See Figures 9.2, 9.3, and 9.4.

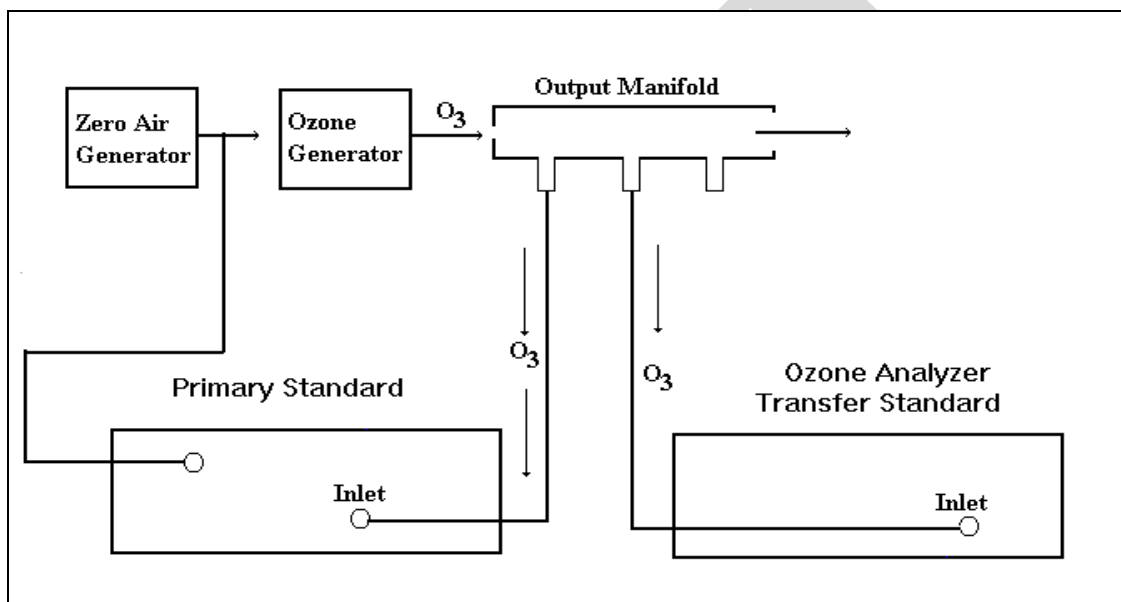

Figure 9.2 Calibration of an ozone analyzer-type transfer standard

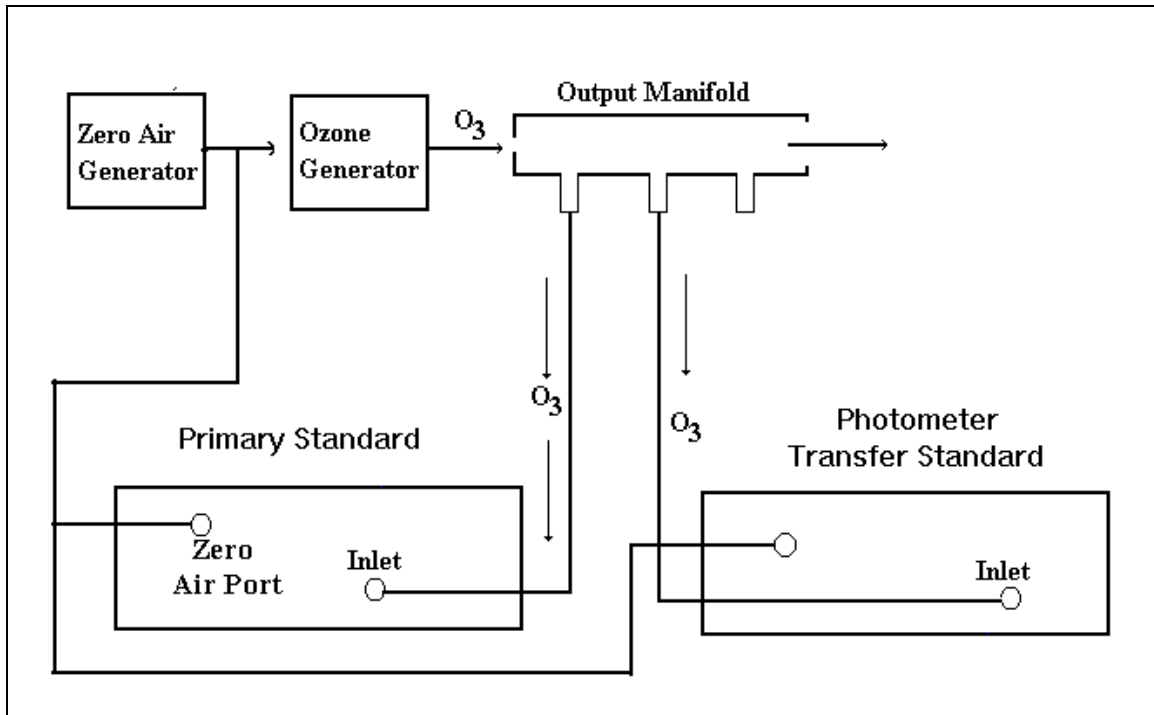

Figure 9.3 Calibration of a photometer-type transfer standard

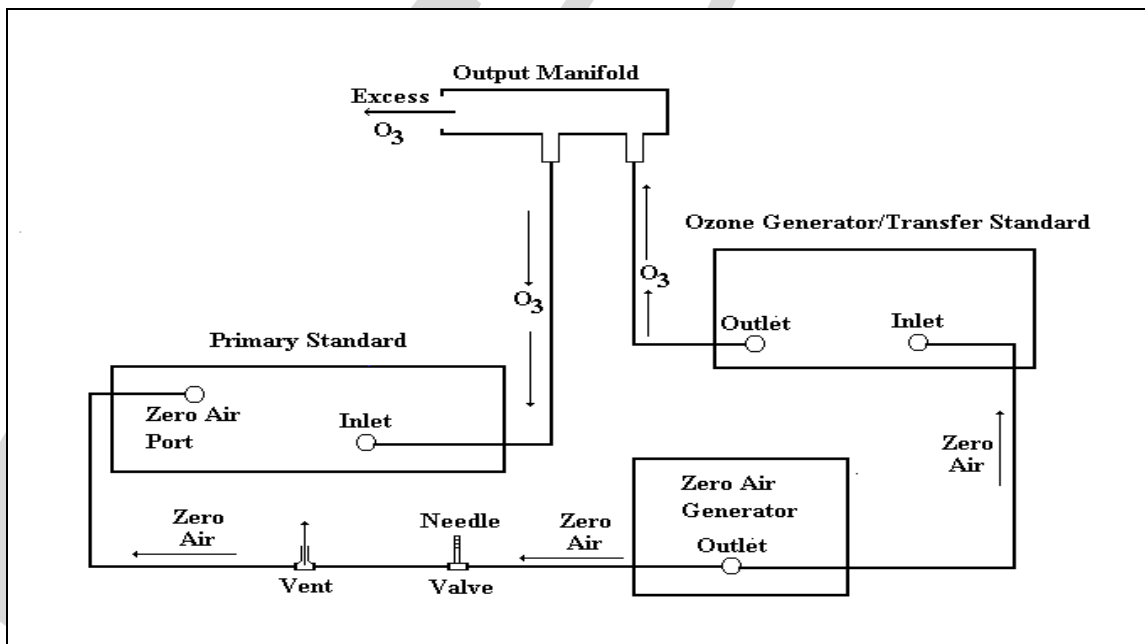

Figure 9.4 Calibration of an ozone generator-type transfer standard

- ! Allow the transfer and primary standards to warm up properly. Generally, one hour is sufficient. Consult the manufacturer's operating manual for details.
- ! Record the span and the count frequency settings, temperature, and barometric pressure (if applicable) on both the primary and transfer standards.
- ! Attach the inlet of the primary and transfer standard to the ozone manifold. Make sure that there is proper venting of ozonated air.
- ! With the ozone lamp off, allow both the primary and the transfer standards to stabilize to zero air. Record 10 readings from the primary and the transfer standard simultaneously. (If an ozone generator is used as a transfer standard, a control setting rather than a reading may need to be recorded.)
- ! After 10 readings have been recorded, switch on the ozone lamp and set the lamp for 80-90% of the full scale of the ozone transfer standard.
- ! Allow the primary and the transfer standard to stabilize at this ozone concentration and record 10 readings from the both instruments simultaneously.
- ! Repeat the two previous steps at each of at least four lower ozone concentrations.
- ! After six concentrations of ozone have been tested against the primary and transfer standard and all values have been recorded, turn off the ozone lamp and allow both instruments to sample zero air.
- ! Record the temperature and barometric pressure of the primary standard once the tests are finished. Then examine the data for evidence of temperature or pressure instability.
- ! Average all data points at each level. Perform a linear regression on this data set, following instructions given in Reference 2.
- ! Repeat this entire procedure on five more days within a two-week period to complete the 6x6.

9.2 Ozone Analyzer Calibration

Once a primary standard and all transfer standards have been selected and authority established, the ozone analyzer can be calibrated by referencing its ozone response at the monitoring station against the transfer standard.

The following precautions should be observed when calibrating an ozone analyzer against a transfer standard.

- ! The transfer standard must not also be used as an analyzer to collect data. If so, its authority as a transfer standard is voided.
- ! Documentation of calibration of the transfer standard against the local primary standard or SRP should be kept with the transfer standard, usually in a folder or logbook.

- ! The air sampling manifold must have an opening large enough so that excess air can leave the manifold without back pressure.
- ! Many agencies use an on-site mass-flow controlled calibration unit with an ozone generator to generate ozone standard concentrations. If no such ozone source is available, then use either the ozone generator of the transfer standard or the one built into the photometer.
- ! If the transfer standard has an ozone generator and manifold, then use as short a length of tubing as possible from the manifold to the analyzer to reduce loss of ozone in the line.
- ! If an independent generator is used for ozone formation, then lines to the analyzer and transfer standard should be approximately the same length.
- ! Perform a multipoint calibration at least every six months. See Section 9.2.1 for details.
- ! When an ozone analyzer is attached to a Data Acquisition System (DAS), ozone values are displayed on a computer screen or printout. To avoid potential confusion, always use the same DAS display channel for displaying ozone data.

9.2.1 Multipoint Analyzer Calibrations

A multipoint calibration includes a minimum of four points (three spaced over the expected range and a zero point), each collected simultaneously from the transfer standard and the ozone analyzer. Although five to seven points are preferable, current analyzers are very linear over their entire operational range. The following steps outline the multipoint calibration procedure.

- ! Allow both the transfer standard and the ozone analyzer to warm up properly. Usually, one hour is sufficient but consult the manufacturer's instruction manual for specific details.
- ! Record the span and frequency setting and the temperature and barometric pressure (if available) for the ozone analyzer and transfer standard, to use as QC checks.
- ! If using an on-site ozone generator, flood the manifold and attached ozone analyzer with ozone. Then attach the transfer standard to the manifold. Take readings and compare. If the photometer has a built-in ozone generator, then attach the inlet of both the photometer and the analyzer to the internal manifold of the photometer. Make sure there is proper venting of any excess ozonated air.
- ! If the station is equipped with an on-site calibration unit, start production of zero air, mark the strip chart, and flag the DAS data. With the ozone lamp off, allow both ozone analyzer and transfer standard to stabilize to zero air. When stability is satisfactory, record 10 readings from the DAS ozone channel and transfer standard simultaneously.
- ! Switch on the ozone lamp and set it to 80-90% of full scale of the transfer standard. Allow the analyzer and transfer standard to stabilize at this reading.
- ! Then record 10 readings from the DAS ozone channel and the transfer standard simultaneously.
- ! Lower the ozone lamp setting to 40-50% of full scale. Repeat the previous two steps.
- ! Lower the ozone lamp setting to 15-20% of full scale. Repeat as above.

Once three ozone levels are tested and all values recorded, turn off the ozone lamp and allow both instruments to sample zero air to see if the baseline of the transfer standard has drifted. Once the tests are completed, record the temperature and barometric pressure (if available).

Perform a linear regression and report both the raw data and the regression results to the data handling group. Acceptance criteria for the linear regressions are left to the discretion of the monitoring agency, but the following are suggested: slope, 1 ± 0.10 ; intercept, ± 0.010 ; correlation coefficient, > 0.995 . Whatever criteria are selected, the instrument still must pass audit tests, which require a difference of no more than $\pm 15\%$. These regular multipoint calibrations must be done at least every six months. In between times, however, other calibrations and checks are used whenever analyzer zero or span drift has been detected.

9.2.2 Level I Calibrations

Level I calibrations consist of a zero-air point and an upper-level point, usually between 75% and 90% of full scale. With the integration of DAS hardware and software, they can be performed automatically. A DAS calibration system is especially recommended for greater precision and accuracy at remote locations. Many of these systems are available commercially. See Figure 9.5.

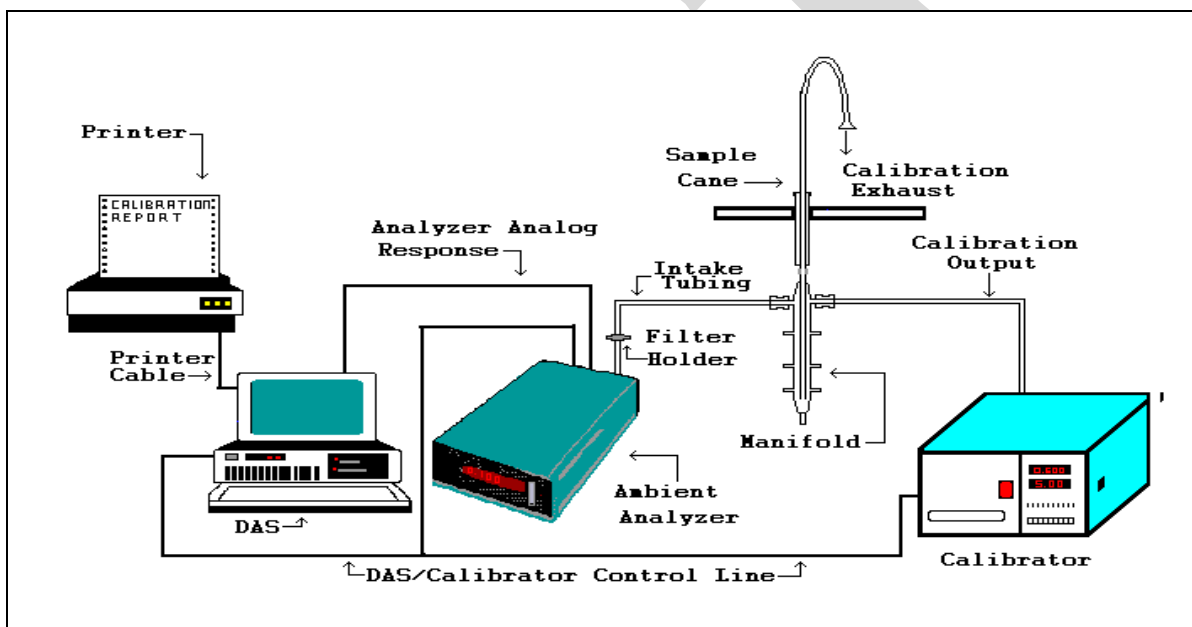

Figure 9.5. DAS calibration system

9.2.3 Calibration/Certification of On-Site Transfer Standard

If an ozone generator is used as the ozone source, there must be some method to transfer authority from a mobile transfer standard to an on-site transfer standard. This can be done by generating ozone with the on-site generator and allowing the transfer standard to sample the ozone concentrations at different levels. If this calibration is performed quarterly, the authority from the mobile transfer standard can be transferred to the on-site generator. Then the DAS-generator combination can be set up to perform automated Level I calibrations as specified by the operating agency. If an operator performs Level I calibrations manually, the transfer standard can be substituted for the calibrator.

9.2.4 Level II Zero/Span Checks

Level II zero/span checks are quick tests used to detect analyzer drift. They cannot be used for data validation, however, because they use an uncertified ozone standard not traceable to a primary standard.

Drift

10.0 ANALYZER OPERATION AND MAINTENANCE

Field operators should consult the manufacturer's operations manual for detailed, step-by-step instructions on how to use their particular analyzer. This Section discusses topics that are more generally applicable to analyzers as a whole.

10.1 Typical Analytical Cycle

A summary of one analytical cycle for a single-path instrument widely used in the determination of ozone in ambient air is described below. See also Figure 10.1

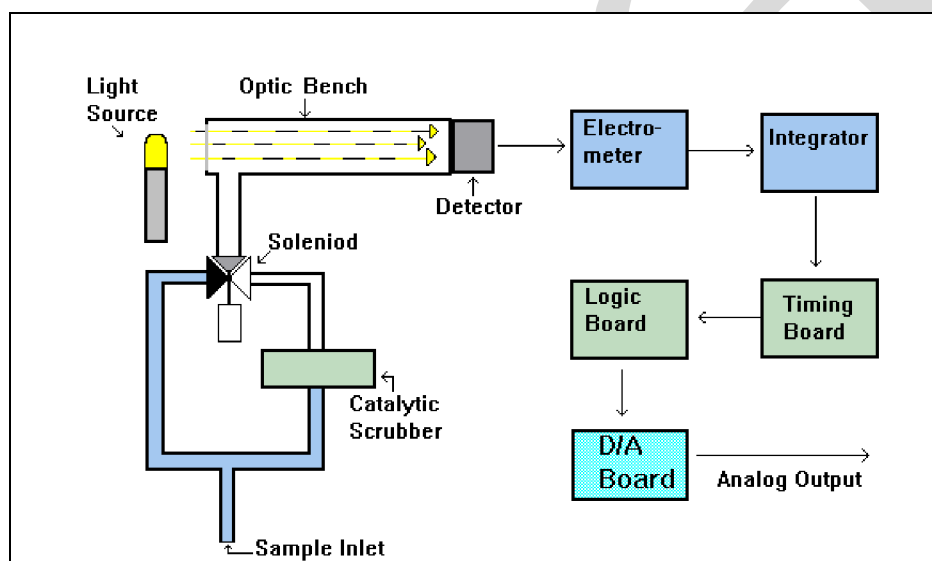

Figure 10.1 Ozone analyzer

The ozone analyzer is assumed to be attached to a data acquisition system (DAS). A timing circuit board regulates the analyzer cycle, which begins with the integrators cleared and deactivated. The memory circuit, digital display, and analog converter hold the values measured in the preceding cycle. The solenoid valve is then de-energized and sample air is drawn through the ozone scrubber into the absorption chamber. After the absorption chamber is purged with scrubbed air for a given time (usually 5-10 seconds), the integrators receive a signal to begin. They then measure the light transmittance received by the 254 nm wavelength-specific detector and transfer it to the logic board for storage.

After a pre-set time, often about 5 to 20 seconds but depending on the instrument, the solenoid is energized. The sample air is allowed to flood the optic chamber. If ozone is present in the sample air, the transmittance will be less. A ratio is then derived and the concentration calculated automatically.

On-board electronics can measure environmental conditions inside an instrument and adjust the output accordingly. Some ozone analyzers, for instance, automatically correct the output for the internal temperature and barometric pressure of the optic cell.

10.2 Routine Checks

To determine whether the analyzer is working properly, field operators perform many routine operations every time they visit the monitoring station. Each agency needs to develop maintenance checklists or electronic spreadsheets to document that all required checks have been made. The lists and sheets should be useful both for collecting data and for assessing the quality of that data. Management **must** review them regularly and change them if necessary. See Figure 10.2 for an example of a checklist for ozone analyzers.

Checklist for Ozone Analyzer								
Station Name _____				Month/Year _____				
Station ID Number _____				Technician _____				
Instrument Make/Model _____				Serial No. _____				
Date	Air Flow	Chart Traces	Filter Change	Temp.	Pressure	Zero	Span	Leak Check

Instructions: Record dates of the following performance checks:

Daily Checks: Air flow, Strip chart traces

Weekly Checks: Filter change, Temperature, Pressure, Zero, Span

Quarterly Checks: Solenoid valve leak test

Semi-Annual Checks: Multipoint Calibration _____

Clean fan, fan filter _____

Clean optical system _____

Replace zero air scrubber _____

Inspect all tubing _____

Comments:

Figure 10.2 Example of a quality control and maintenance record

10.3 Preventive Maintenance

Preventive maintenance should **prevent** down-time and data loss. Management and field operators should jointly develop their preventive maintenance program. A program designed by persons unfamiliar with analyzer operations may include unnecessary items or omit mandatory ones. Table 10-1 illustrates items that monitoring agencies should include in their ozone preventive maintenance program.

Table 10.1 Example of a Preventive Maintenance Schedule for Ozone Monitoring

Item	Schedule
Replace particle filter	Weekly
Perform Level I calibration*	Weekly
Perform electronic parameter checks	Weekly
Clean fan/fan filter	Semi-annually
Clean optic bench	Semi-annually
Perform multipoint calibration	Semi-annually
Replace zero air scrubber	Semi-annually
Inspect internal, external tubing; replace if necessary	Semi-annually
Replace UV lamp	As needed
Replace solenoid	As needed
Rebuild or replace pump	Every two years

* Weekly Level I calibrations should be performed only if nightly automated Level I calibrations are not performed.

In addition to a schedule, the preventive maintenance plan should also include more detailed task descriptions, such as illustrated below:

- ! Clean the optical cells with optical cleaning paper and Teflon tubing to prevent scratching. The operator should be able to clean the cells easily and to re-install them without leaks.
- ! Because the analyzer pneumatic system requires so much preventive maintenance, the tubing, solenoids, and pump should be inspected regularly. Cracked tubing, loose fittings, and faulty solenoids can cause the instrument to analyze room air rather than sample air and lead to invalid data. Particles in the solenoid valve can cause an erroneous analyzer response because the valve may not close completely. A faulty pump or rotameter can also cause problems with pneumatic systems. When oscillations in the rotameter force the operator to adjust the rotameter continually, the pump is failing and should be either repaired or replaced.
- ! Always operate ozone analyzers with zero-air scrubbers. Change the scrubbers regularly, depending on usage, but at least every six months and before calibrations.

Consult the analyzer operations manual for complete details on operation and maintenance.

11.0 HANDLING AND PRESERVATION

As described in Section 10, atmospheric ozone concentrations are monitored continuously; no discrete samples are collected, handled, or preserved. Therefore an SOP for this ozone by UV method does not need a section on Handling and Preservation.

draft

12.0 SAMPLE PREPARATION AND ANALYSIS

As described in Section 10, ozone samples receive no special preparation prior to analysis. Therefore an SOP for this ozone by UV method does not need a section on Sample Preparation and Analysis.

draft

13.0 TROUBLESHOOTING

Ozone analyzers are subject to many factors that can cause inaccurate measurements or down-time. Consult the manufacturer's operations manual for detailed descriptions of troubleshooting procedures. The following text and table provide guidance on some of the more common problems likely to be encountered.

13.1 Environmental Factors

When troubleshooting, an operator must constantly think about environmental factors that may affect the instruments.

- ! Is the shelter temperature fluctuating too much (more than, say, 2-3°C)?
- ! Is vibration from other equipment causing problems?
- ! Is voltage to the instrument stable? Power fluctuations in the 110V line can cause erratic performance.
- ! Is the air conditioning system blowing on the instrument, especially at a particular time each day?
- ! Does opening the door of the shelter cause variations of the data collected?

Environmental factors can also cause sporadic problems that can be difficult to diagnose. For instance, sunlight shining on an instrument may heat it, causing a temperature change and invalid readings. But as the sunlight moves away from the instrument, the problem disappears.

13.2 General Factors

Other factors linked to shelter and sampling manifold design can contribute to data loss. Ozone values can be low if the sample probe, manifold, and lines are dirty, cracked, or leaky. The sample probe and manifold should be cleaned every six months. Teflon lines should be replaced every two years. The 10-micron filters used in the sampling train to remove fine particles may need to be replaced as often as every two weeks, depending on the condition of the filter and the particulate loadings around the monitoring site.

13.3 Instrument Troubleshooting

Table 13-1 summarizes common problems seen with ozone analyzers and photometers, possible causes, and possible solutions. More specific information can be found in the manufacturer's operations manuals.

Table 13-1. Instrument Troubleshooting for Ozone

Problem	Possible Cause	Possible Solution
Negative values	Weak UV lamp	Replace lamp
	Bad solenoid valve	Replace valve
	Low reading	Replace worn zero air scrubber
	Drifting photometer	Check electrometer voltage
	Flow rate too high	Decrease flow rate
	Flow rate too low	Increase flow rate
No display	No voltage to motherboard	Check power supply
	Bad power supply board	Replace power supply board
Excessive noise	Dirty optics	Clean optic bench
	Erratic block heater	Replace block heater
	Erratic lamp voltage	Check lamp driver board
	Leak in pneumatics	Perform leak test
Pump not working	A short in pump windings	Replace pump
	Pump bearings frozen	Replace pump bearings
	Pump diaphragm worn	Rebuild pump head
	Leak in pneumatics	Perform leak test
Photometer lamp will not light	Bad lamp driver	Replace lamp driver board
	Bad lamp	Replace lamp
No ozone readings	Saturated detector	Adjust detector
	Defective timing board	Replace board
	UV lamp not lit	Check electronics; replace lamp
Zero, then random, readings	Leak in pneumatics	Fix leak
	Defective timing board	Replace board

14.0 DATA ACQUISITION, CALCULATIONS, AND DATA REDUCTION

In the past, the most effective way to collect ozone data was on strip chart recorders. Today, due to advances in data storage and retrieval systems, most strip chart recorders are used as back-up systems. Some present-day electronic data acquisition systems (DASs) are less expensive than a high quality strip chart recorder. Any DAS should still be used with a backup system as protection against data loss due to system failure.

14.1 Data Acquisition

Electronic data acquisition systems are widely used, and as shown below, have many advantages over strip chart recorders.

- ! Accuracy. A properly operating DAS usually collects data at rates of several times per second. The one-second values are calculated and stored until the end of the hour when the hourly ozone value is computed automatically. These hourly averages are more accurate than those from a strip chart because no human interpretation is involved.
- ! Data collection options. Instantaneous, short-term, and hourly data are collected and stored.
- ! Data flags. Data review parameters, such as maximum and minimum values, can be written into the software code to screen and flag suspect data.
- ! Long-term storage. Data can be stored indefinitely to provide a long-term storage device for many years of data.
- ! Spreadsheet capability. Newer systems allow calling up several parameters at one time to compare factors such as meteorological conditions by using a spreadsheet type of presentation.
- ! Calibration control. A DAS can control calibration equipment and record calibration data as they are being collected, making an excellent tool for use in remote locations.

14.2 Calculations and Data Reduction

The latest generation of data acquisition systems can be accessed remotely via modem and software so that a remote user can monitor pollutant levels and see the results of automatic calculations on a real-time basis.

Calibration checks are used as an indirect verification of DAS software and hardware. If a check is satisfactory, the entire data collection system, including the DAS, is assumed to be operating properly. If not, a search for the cause of the problem begins. Occasionally, a DAS chip fails and the board holding it has to be replaced.

Ozone data, like that for other gaseous criteria pollutants, are stored as hourly averages. Even if the proposed 8-hour ozone standard is promulgated, States and local agencies will continue to report hourly averages to the EPA Aerometric Information Retrieval System (AIRS), which will perform the 8-hour calculations.

Most agencies already use central processing and polling software that will allow their central computer to do the 8-hour averaging. If not, they should consider requiring the ability to generate 8-hour averages as part of any DAS purchase package. They then will be better able to manipulate their data for their own use.

15.0 COMPUTER HARDWARE AND SOFTWARE

DAS hardware and software used by most monitoring organizations to collect data and control station operations were discussed in general in Section 14. In preparing SOPs, Sections 14 and 15 can be combined if the merger gives a better presentation.

Several manufacturers now offer a data link for remote access. Although remote access is a rapidly growing trend, it must be used cautiously because it involves changing the internal settings of the instruments. Only qualified personnel who fully understand the implications of such changes should have access to these data links.

16.0 DATA MANAGEMENT AND RECORDS MANAGEMENT

16.1 Data Management

Ozone measurements, collected over 5- to 20-second intervals, are reported as hourly averages. Approximately 720 hourly averages of ozone monitoring data are collected every month. Thus, an analyzer operating over many months produces a large amount of data for each site.

Although monitoring agencies submit their data to the EPA centralized AIRS data base, they also need to maintain their data locally for their own use. Computer systems with large hard drives are needed. Agencies should install computers and collect data on a commercially available DAS to lessen the burden of handling vast quantities of data. Data should be downloaded from the field DAS to a central data storage facility. See Section 14 and Figure 16.1 for additional information on data flow through a DAS.

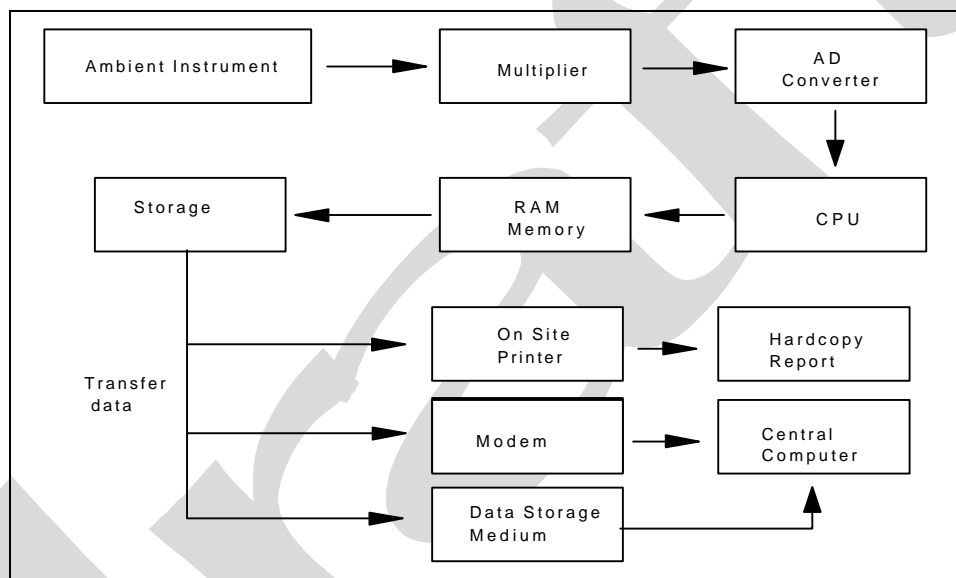

Figure 16.1 Data flow through a data acquisition system

Figure 16.1 shows the data flow from the analyzer through the DAS (multiplexer, A/D converter, CPU, RAM memory, storage medium) to a printer, modem, or an external data storage medium such as a diskette or CD-ROM.

Security is a critical issue that cannot be ignored. Many agencies have central computer systems that access and download data remotely and then store a backup data file at the central facility. They must take proper precautions to protect both the remote and the central data collection systems.

16.2 Records Management

Once data have been reviewed and approved, they should be archived for a pre-specified amount of time, usually five years. Electronic data should be downloaded to storage drives in the central facility with remote access capability. Backup copies of data should be stored on diskettes, tapes, or other suitable media at a different location. Calibration data for instruments, transfer standards, and primary standards should also be stored electronically. Strip charts should be stored in a dry, secure storage area. Hard copies of reports should be generated and stored in a secure environment.

17.0 QUALITY ASSURANCE AND QUALITY CONTROL

Quality assurance (QA) and quality control (QC) are two terms commonly discussed but often confused. Quality **assurance** refers to the overall process of ensuring that the data collected meet previously stated measurement quality objectives (MQOs). Quality **control** covers specific procedures established for obtaining and maintaining data collection within those limits.

Clear communication among all participants is crucial. When all groups perform their jobs correctly and communicate clearly with each other, they form the vital control loop required for any good QA/QC program.

17.1 Quality Assurance

There are six commonly used data quality indicators for ozone and other pollutants. Collectively, the first five--precision, accuracy, representativeness, completeness, and comparability-- were once called "PARCC". Although the term is used less frequently now, it still is a useful designation. The sixth is method detection limit, also called detectability. Application of each of these terms to ozone measurements is shown in Table 17-1 that summarizes requirements specified in various sections of the *Code of Federal Regulations*, and then discussed in the following sections.

17.1.1 Precision

Precision is defined as the measure of agreement among individual measurements of the same property taken under the same conditions. For ozone, this refers to testing the ozone analyzer in the field at a concentration between 0.080-0.100 ppm. The test must be performed at least once every two weeks, and is used to calculate the 95% probability limits for the data. Precision tests also check for bias, defined as the systematic error in test results. See Part I, Section 6.0, and also Volume I, Section 7, of the QA Handbook¹² for more details.

17.1.2 Accuracy

Accuracy is defined as the degree of agreement between a measured value and the true, expected, or accepted value. Quantitative comparisons are made between the measured value and the true, standard value during audits. Generally, three upscale points and a zero point are compared. Two audit types commonly used for ozone, direct comparison and blind, are discussed below. The SOP should discuss plans for each type of audit.

- ! ***Direct Comparison Audits:*** A transfer standard and the monitoring station's ozone analyzer then assay the same ozone concentrations at the same time. The responses of the on-site analyzer are then compared against the output of the transfer standard and a linear regression is generated. See Part I, Appendix A for more details on audit procedures.
- ! ***Blind Audits:*** In blind audits (also called performance evaluation audits), auditees do not know the ozone concentrations produced by the auditor's equipment. An ozone generator produces ozone concentrations to be measured by the station analyzer. Responses of the on-site analyzer are then compared against those of the generator and a linear regression is calculated. See Part I, Appendix A, for more details.

Table 17-1. Data Quality Requirements for Ozone

Requirement	Frequency	Acceptance Criteria	Reference	Information or Action
Precision	Once every 2 weeks	Conc 0.08-0.100 ppm; 95% probability limits within 15% of the mean	40 CFR 58, App. A	If 95% confidence limits fail, implement QC.
Accuracy	SLAMS, once a year PSD, quarterly	Slope: 1.00 +/- 0.15 Intercept: +/- 0.003 ppm Regression: > 0.9950	Part I, Section 18, App. A	Use photometer or generator calibrated against local primary standard or EPA SRP.
Representativeness	--	Dependent on siting criteria	40 CFR 58, App. D	
Completeness	Daily, monthly	SLAMS, 75% PSD, 80%	40 CFR 50, App. H.3 PSD Regulations, EPA 450/4-87-007	
Comparability	--	Must be reference or equivalent method	Part I, Section 7.3	
Method Detection Limit		0.005 ppm	40 CFR 53.23b	

17.1.3 Representativeness

Representativeness refers to whether the data collected accurately reflect the conditions being measured. It is the data quality indicator most difficult to quantify. Unless the samples are truly representative, the other indicators are meaningless. Representativeness for ozone is assured, as best as possible, by precise definitions of monitor siting criteria, using several scales: middle, neighborhood, urban, and regional. Siting criteria for ozone monitors are discussed further in Part I, Sections 6 and 7.

17.1.4 Completeness

Completeness is defined as the amount of data collected compared to a pre-specified target amount. Ideally, 100% of the target amount of data would always be collected; in practice, that value is less for many reasons, ranging from calibration time and site relocation to power outages and equipment failure. For ozone, EPA requires a minimum completeness of 75% (40 CFR 50, App. H.3). Typical completeness values can approach 90-93%.

17.1.5 Comparability

Comparability is defined as the process of collecting data under conditions that are consistent with those used for other data sets of the same pollutant. The goal is to ensure that instruments purchased and operated by states and local agencies produce comparable data. All monitoring agencies must purchase instruments that have been designated by EPA as reference or equivalent methods. See Part I, Sections 6 and 7.3 for additional details.

17.1.6 Method Detection Limit

The method detection limit (MDL) or detectability refers to the lowest concentration of a substance that can be determined by a given procedure. Because there are several different definitions of MDLs and the resulting values may also differ, any method used for ozone must be able to detect a minimum value of 0.005 ppm of ozone (40 CFR 53.23b). Most instruments do somewhat better than that.

17.2 Quality Control

As stated earlier, quality control (QC) refers to procedures established for collecting data within pre-specified tolerance limits. Almost all QC procedures have already been covered under specific topics throughout this guidance document. Documentation and standard operating procedures, however, are discussed below because they apply to many topics.

17.2.1 Documentation

Documentation, unfortunately, is the aspect of a QA/QC program most often slighted. Yet it is even more important for ozone than for other criteria pollutants because there are no locally available NIST standards for ozone. Extensive certification paperwork must be rigorously maintained for each transfer standard, local primary standard, and analyzer, and for verification tests with SRPs or with a local primary standard of other organizations.

Monitoring agencies should take special care to prepare and preserve backup copies of all data, especially calibration data. All data and supporting documentation should be held for five years. See Section 16 for additional information.

17.2.2 Standard Operating Procedures

To assist Handbook users in preparing their own SOPs, this guidance document is written using the current EPA-suggested format and sequence for preparing SOPs¹³. All agencies and consultants that perform ozone monitoring should develop their own written SOPs tailored to their specific needs and conditions. The SOPs for ozone should include, but are not limited to, the following topics.

- ! Primary standard verification
- ! Transfer standard verification
- ! Ozone analyzer preventive maintenance
- ! Ozone analyzer operation and scheduling
- ! Documentation procedures
- ! Internal audit procedures
- ! Precision testing
- ! Data review and validation

Time and effort well spent in preparing SOPs will save far more time and effort in operating the monitoring program.

REFERENCES

1. Sexton, F.W., F.F. McElroy, R.M. Michie, Jr., V.L. Thompson, and J.A. Bowen. 1981. Performance test results and comparative data for designated reference and equivalent methods for ozone. EPA-600/4-83-003. U.S. Environmental Protection Agency, Research Triangle Park, NC 27711.
2. McElroy, F.F. 1979. Transfer standards for calibration of air monitoring analyzers for ozone. Technical assistance document. EPA-600/4-79-056. U.S. Environmental Protection Agency, Research Triangle Park, NC 27711.
3. Kleindienst, T.E., E.E. Hudgens, D.F. Smith, F.F. McElroy, and J.J. Bufalini. 1993. Comparison of chemiluminescence and ultraviolet ozone monitor responses in the presence of humidity and photochemical pollutants. *Air & Waste*, 43: 213-222.
4. Hudgens, E.E., T.E. Kleindienst, F.F. McElroy, and W.M. Ollison. 1994. A study of interferences in ozone UV and chemiluminescent monitors. EPA/600/R-94/136. Proceedings, U.S. EPA/A&WMA International Symposium, Measurement of Toxics and Related Air Pollutants. Durham, NC.
5. Kleindienst, T.E. 1995. Issue Paper: Evaluation of reliability of ozone measurements from UV and chemiluminescence monitors. ManTech Environmental Technology, Inc., Research Triangle Park, NC 27709.
6. Leston, A., and W. Ollison. 1992. Estimated accuracy of ozone design values: are they compromised by method interferences? *Air & Waste Management Association Conference on Tropospheric Ozone: Non-Attainment and Design Values*. October 27-30. Boston, MA.
7. Meyer, C.P., C.M. Elsworth, and I.E. Galbally. 1991. Water vapor interference in the measurement of ozone in ambient air by ultraviolet absorption. *Review of Scientific Instruments*. 62(1):223-228.
8. Paur, R.J. and F.F. McElroy. 1979. Technical assistance document for calibration of ambient ozone monitors. EPA-600/4-79-057. U.S. Environmental Protection Agency, Research Triangle Park, NC 27711.
9. Protocol for the recertification of standard reference photometers in the EPA standard reference photometer network. 1996. TRC Environmental Corporation. Chapel Hill, NC 27514.
10. Standard reference photometer for verification and certification of ozone standards. Standard operating procedures. Draft report. 1995. TRC Environmental Corporation. Chapel Hill, NC 27514.
11. See Reference 2, Section 4.
12. Nees, M. 1994. *Quality Assurance Handbook for Air Pollution Measurement Systems*. Volume I, A Field Guide to Environmental Quality Assurance, Section 7. U.S. Environmental Protection Agency, Research Triangle Park, NC 27711.

13. Guidance for the Preparation of Operating Procedures for Quality-Related Operations. 1995. EPA QA/G-6. U.S. Environmental Protection Agency, Washington, DC 20460.

Draft